

# MiniCODER

Configurable speed and position sensor with Mitsubishi interface

GEL 244xM

## Technical information

Version 2024-05-21

### General

- The measuring system comprises a MiniCODER and a target wheel for attachment to machine shafts.
- The MiniCODER scans the target wheel with magnetoresistive sensors without contact and detects the direction of rotation, speed and position.
- The MiniCODER can be adjusted and configured with the GEL 211CST4\_2M mobile service unit.

### Properties

- MHSSI (Mitsubishi High Speed Serial Interface)
- Maximum permissible rotational speed:  
Up to  $100,000 \text{ min}^{-1}$  <sup>(1)</sup>
- Resolution: Up to 26 bits
- Operating temperature range:  $-30 \text{ °C}$  to  $+105 \text{ °C}$
- Degree of protection: IP 68
- Position determination by reference mark detection

### Advantages

- Maintenance-free electronics
- Wear-free mechanics
- Low temperature drift and high signal quality
- Highest interference immunity due to completely screened metal housing
- Fast commissioning of the configurable MiniCODER in the assembled state without opening the spindle with mobile service unit
- High design flexibility due to customized manufacture of target wheels

### Field of application

- Position and rotational speed measurement in machine tool manufacturing

**i** All trademarks/brands quoted in this document are the property of their respective owner. Protected trademarks/brands are not marked as such in this document.

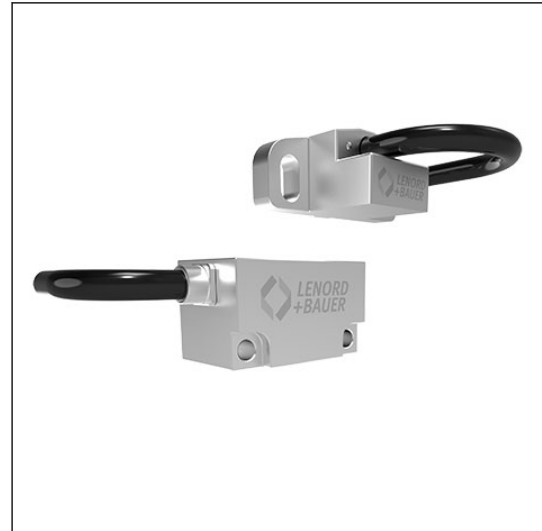

MiniCODER GEL 2449M/GEL 2444M

<sup>(1)</sup> Depending on the selected optional extras Mechanically permissible speed depending on the design of the target wheel (see Technical Information ZAx/ZFx (DS51–ZAx/ZFx)).

*Right to technical changes and errors reserved.*

# General description

## Product construction

MiniCODERs are intended for contactless measurement of rotational or linear movements mainly in machines, gear units, motors or high-speed spindles. They are manufactured using the latest micro system technology and are fully encapsulated, making them particularly insensitive to shocks and vibrations.

## Measuring system

The measuring system comprises a MiniCODER and a target wheel. The system does not require dedicated bearings, as the target wheel is mounted directly on the machine shaft.

The measuring system works without contact and is wear-free with maintenance-free electrical parts. It detects the direction of rotation, rotational speed and position of a rotating machine shaft.

The target wheel is made of ferromagnetic material and must be ordered separately.

The MiniCODER has a magnetic field that is changed by the rotating target wheel. The sensor detects the magnetic field change and the integrated electronics convert this into corresponding output signals.

External evaluation electronics can read in the output signals and determine the direction of rotation, rotational speed and position of the machine shaft.

A defined air gap between target wheel and MiniCODER is required for contactless measurement. To facilitate assembly, a corresponding distance gauge is included with the MiniCODER.

## Reference mark

The MiniCODER can determine the machine shaft position by detecting a reference mark.

## Module

The MiniCODER must be ordered to match the design of the reference mark and to match the module of the target wheel.

## Explanations about the target wheel

### Target wheels

For the detection of rotatory movements, MiniCODERs form a unit together with target wheels. The target wheel size and thus the diameter depend directly on the module and the number of teeth.

### Standard target wheels

Standard target wheels are available at short notice ex factory. Specifications and designs see "Technical information ZA<sub>x</sub>/ZF<sub>x</sub> (DS51-ZA<sub>x</sub>/ZF<sub>x</sub>)".

### Customized target wheels

Customized target wheels are manufactured individually according to customer requirements. Please send a design drawing of your target wheel to [info@lenord.de](mailto:info@lenord.de).

### Reference marks

The MiniCODER can detect reference marks of the lug or tooth form. The detected reference signal can be used to reference the position. This is required, for example, for automatic changing of a tool on a milling or grinding spindle.

Selection of the reference mark is determined by the size and rotational speed of the target wheel used, as both

affect the forces acting on the reference mark. For new designs, we recommend using a target wheel with reference mark variant "Z".

### Reference mark N – lug

A metal lug integrated in the target wheel, whose position is exactly between two teeth, is detected. The lug must be made of ferromagnetic material and must not protrude beyond the tip circle of the target wheel. Due to the forces acting on the reference lug, the use of this variant is only permissible in a very limited rotational speed range.

### Reference mark Z – tooth on tooth

These target wheels are made from a single piece.

### Module

The module is a tothing dimension for target wheels and describes the relationship between the number of teeth and the pitch diameter of the target wheel. For the same number of teeth, the smaller the module, the smaller the outside diameter.

**i** The MiniCODER must be ordered to match the design of the reference mark and to match the module of the target wheel.

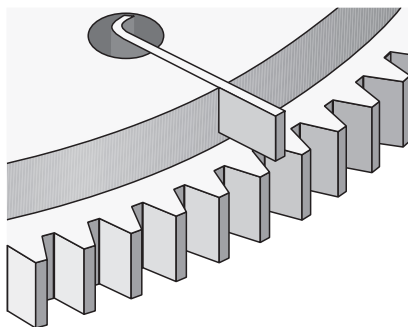

N = reference mark – lug

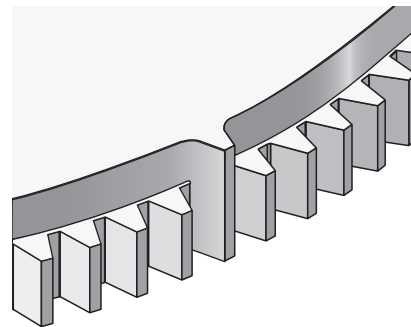

Z = reference mark – tooth  
Standard target wheel

# General description

## Connection types

L = Cable length



The connection cable screen is electroconductively connected to the MiniCODER housing.

## Connection example with GEL 2449M

Cable outlet MiniCODER	Cable design	Connection type
L (tangential left)	— (without temperature sensor cable)	Z (10-pin male connector)

## Assignments

### Connection type K

Flying lead (10-pin female connector <sup>1)</sup> ) (plug-in view)	Pin	Core color	Signal/Function	
	1	red	$U_B$	+5 V supply voltage
	2	white	RQ+	Positive request signal
	3	brown	RQ-	Inverse request signal
	4	pink	Data+	Positive data
	5	black	Data-	Inverse data
	6	green	n.c.	unallocated
	7	gray	n.c.	unallocated
	8	yellow	n.c.	unallocated
	9	blue	0 V	GND
	10	unallocated		

<sup>1)</sup> The delivery takes place with connected test connector from Lenord+Bauer.



If a mobile service unit is to be used for the function test, the test plug must not be removed!

# General description

## Connection type Z

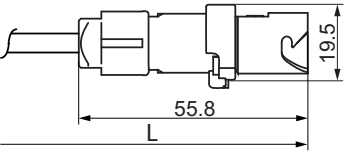
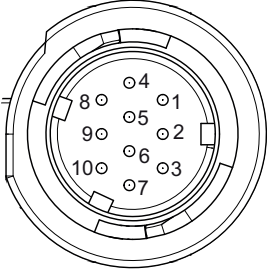
10-pin male connector (plug-in view)	Pin	Signal/Function	
	1	n.c.	unallocated
	2	n.c.	unallocated
	3	RQ+	Positive request signal
	4	RQ-	Inverse request signal
	5	Data+	Positive data
	6	Data-	Inverse data
	7	U <sub>B</sub>	+ 5 V power supply
	8	0 V	GND
	9	Screen	Screen
	10	n.c.	unallocated

# General description of the MHSSI interface

## Signal pattern M

The MiniCODER GEL 244xM is a digital encoder kit with reference signal. It transmits data via a digital interface (Mitsubishi High Speed Serial Interface).

Data transmission only takes place upon request. The MiniCODER decodes incoming requests (RQ+/RQ-) from a higher level control system and then sends the requested data (Data+/Data-) to the higher level control system.

The MiniCODER can be connected directly to the following Mitsubishi higher level control systems:

### Possible applications

Mitsubishi CNC series M800/M80/E80/C80	
Spindle drive	Servo drive
Model <ul style="list-style-type: none"> <li>▪ MDS-E-SP series</li> <li>▪ MDS-EH-SP series</li> <li>▪ MDS-EJ-SP series</li> <li>▪ MDS-EM-SP series</li> <li>▪ MDS-EMH-SP series</li> </ul>	Model <ul style="list-style-type: none"> <li>▪ MDS-E-Vx series</li> <li>▪ MDS-EH-Vx series</li> <li>▪ MDS-EJ-Vx series</li> <li>▪ MDS-EJH-Vx series</li> <li>▪ MDS-EM-Vx series</li> <li>▪ MDS-EMH-Vx series</li> </ul>
Firmware number: BND-1501W202	Firmware number: BND-1501W201
Firmware version: B2 or higher	Firmware version: B2 or higher



### Plug and Play

Any target wheel diameters are possible for freely selectable teeth numbers. The application can be connected directly to Mitsubishi higher level control systems by configuring the measuring system with mobile service unit.

### Alarm and warning table

Alarm number (MiniCODER connected with CN2)	2B	2C	2D	2E	48	49	4 A	4B
Alarm number (MiniCODER connected with CN3)	1B	1C	1D	1E	27	28	29	2 A
GEL 244xM... (ID: 9F)	Signal error	Amplitude warning	EEPROM error	Under voltage	Hardware error	Warning overspeed	Counter error	Temperature warning

### Optional extras H, P

The MiniCODER can be tested and configured with the GEL 211CST4\_2M mobile service unit.

The following functions are available:

- MiniCODER functional test
- Target wheel functional test
- Changing the resolution and the number of target wheel teeth
- Determining the parameters to be set on the higher level control system



If the number of teeth set in the MiniCODER in the factory does not match the number of teeth of the target wheel, the number of teeth in the MiniCODER must be adjusted to the number of teeth of the target wheel using the mobile service unit.

## Mobile service unit GEL 211CST4\_2M



- Analysis, optimization and parameterization of the MiniCODERs with digital RS-422/ RS-485 interface, for example, GEL 244xM
- Compact and mobile
- Plug and play: Connection to the MiniCODER via the external connector; no disassembly required
- Menu-driven adjustment to optimize the signal quality in the installed state
- Checking the quality and installation situation of the target wheel
- Easy operation via SensorDEVICE<sup>UI</sup> in web browser on any end device such as smartphone, tablet or PC; no software installation necessary
- Communication via LAN or WLAN

### Accessories GEL 244\_M

Item no.:	Designation:
ZB2449M1	Adapter cable 3.0 m for <b>GEL 244_M_...Z_...</b> (connection to Mitsubishi higher level control systems)
ZB2449M3	Adapter cable 2.0 m for <b>GEL 244_M_...Z_...</b> (connection to Mitsubishi higher level control systems)
PK211C-244XM-E	PK211C-244XM-E (Ethernet), comprising: <ul style="list-style-type: none"> <li>▪ Mobile service unit GEL 211CST4E2M</li> <li>▪ Universal adapter box, ZB2449M4</li> <li>▪ Power supply unit 5 V, ZB211CB</li> <li>▪ Operating instructions, D-71B-211C or D-53B-211C</li> <li>▪ Case, XW1303</li> </ul>
PK211C-244XM-W	PK211C-244XM-W (WLAN), comprising: <ul style="list-style-type: none"> <li>▪ Mobile service unit GEL 211CST4W2M</li> <li>▪ Universal adapter box, ZB2449M4</li> <li>▪ Power supply unit 5 V, ZB211CB</li> <li>▪ Operating instructions, D-71B-211C or D-53B-211C</li> <li>▪ Case, XW1303</li> </ul>

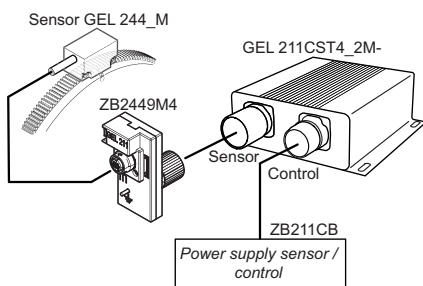

GEL 211CST4\_2M: Connectivity

# GEL 2444M

## Technical data measuring system

	GEL 2444M_...3	GEL 2444M_...4	GEL 2444M_...5
<b>Target wheel</b>			
Material	Ferromagnetic steel		
Target wheel width	10.0 mm		
Reference mark	Lug (N), tooth (Z)		
Module m <sup>(1)</sup>	0.3	0.4	0.5
<b>Geometric data</b>			
Nominal air gap	0.15 mm ± 0.02 mm	0.20 mm ± 0.02 mm	0.20 mm ± 0.03 mm

(1) Other modules upon request



## Technical data GEL 2444M

Electrical data	
Supply voltage $U_B$ (polarity reversal protected, overvoltage protected)	5 V DC $\pm$ 5 %
Current consumption (without load)	$\leq$ 80 mA
Digital interface	RS-485 with Mitsubishi protocol: MHSSI (Mitsubishi High Speed Serial Interface) 2.5 Mbit (RS-422/RS-485 compliant)
Signal identifiers of the interface	Request (RQ): Data request signal from the higher level control system Data (data): Data output from the MiniCODER as a response to the data request signal
Data transmission rate	2.5 Mbit/s
Power consumption without load	$\leq$ 0.5 W
Power-on time	< 0.5 s
Mechanical data	
Housing material	Zinc die casting
Weight	30 g
Maximum permissible rotational speed	$\leq$ 100,000 min <sup>-1</sup> (1)
Cable data	
Cable structure (number of cores x core cross-section)	9 x 0.15 mm <sup>2</sup> [25 AWG]
Cable diameter	5 mm
Minimum bending radius	25 mm
Maximum permissible cable length	$\leq$ 30 m (2)
Ambient data	
Working temperature range	0 °C to +70 °C
Operating and storage temperature range	-30 °C to +105 °C
Degree of protection	IP 68
Dielectric strength	500 V AC; as per DIN EN 61439-1
Electromagnetic compatibility	Electromagnetic emission DIN EN 61000-6-4; DIN EN 61000-6-3 Electromagnetic immunity DIN EN 61000-6-2; DIN EN 61000-6-1
Vibration resistance	200 m/s <sup>2</sup> (EN 60068-2-6)
Shock resistance	2000 m/s <sup>2</sup> (EN 60068-2-27)
MTTF FIT	4,325,201 h at 55 °C 231.203 10 <sup>-9</sup> h <sup>-1</sup> at 55 °C
Approvals	
European Economic Area	Conformity in accordance with EMC Directive 2014/30/EU <b>CE</b>

(1) Depending on the selected optional extras Mechanically permissible speed depending on the design of the target wheel (see Technical Information ZAx/ZFx (DS51-ZAx/ZFx).

(2) Consider voltage drop on the power supply cable; recommended cable length: maximum 2.5 m (no twisted pair)

# GEL 2444M

## Optional extras H

### Configuration

The number of teeth configured in the MiniCODER with optional extras H must match the number of teeth of the target wheel. The resolution is dependent of the maximum speed. The maximum configurable resolution is 26 bits/0.0000054° (67,108,864 positions per revolution).

### Factory settings<sup>(1)</sup>

Designation	Module 3 (m= 0.3)	Module 4 (m= 0.4)	Module 5 (m= 0.5)
Positions per revolution	16777216	16777216	16777216
Resolution	24 bit/0.0000215°	24 bit/0.0000215°	24 bit/0.0000215°
Target wheel tooth number	256	192	150

## Optional extras P

### Configuration

The number of teeth configured in the MiniCODER with optional extras P must match the number of teeth of the target wheel. The resolution is dependent of the number of teeth of the target wheel and the maximum speed. The maximum configurable resolution is 19 bits/0.00068° (524288 positions per revolution).

### Resolution for various applications<sup>(2)</sup>

Application	Standard		Rotational speed					Positioning
Interpolation per tooth cycle	512		256					1024
Target wheel tooth number	128	192	160	204	256	384	512	512
Maximum rotational speed (min <sup>-1</sup> ) <sup>(3)</sup>	41199	27466	65918	51700	41199	27466	20599	5150
Positions per revolution	65536	65536	32768	32768	65536	65536	131072	524288
Resolution	16 bit/0.00549°	16 bit/0.00549°	15 bit/0.0110°	15 bit/0.0110°	16 bit/0.00549°	16 bit/0.00549°	17 bit/0.00274°	19 bit/0.00068°

### Calculation of the maximum rotational speed

$$\text{Maximum rotational speed} = \frac{2.7 \cdot 10^9}{\text{Number of teeth} \cdot \text{Interpolation}} \text{ min}^{-1}$$

### Factory settings<sup>(1)</sup>

Designation	Module 3 (m= 0.3)	Module 4 (m= 0.4)	Module 5 (m= 0.5)
Interpolation per tooth cycle	512	512	512
Target wheel tooth number	256	192	150

### Assignment direction of rotation

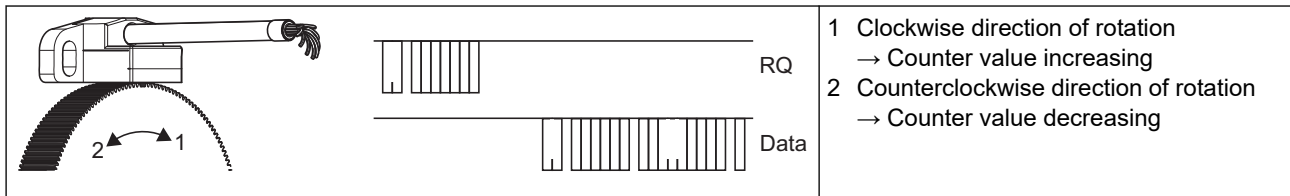

(1) Other factory settings are available upon request.

(2) Configuration with the mobile service unit GEL 211CST

(3) The maximum speed is limited by the internal electronics. The maximum mechanical speed depends on the selection of the target wheel.

## Dimensional drawings

All dimensions in millimeters; general tolerance DIN ISO 2768 – mK

### Dimensional drawing cable outlet MiniCODER: Axial (G)

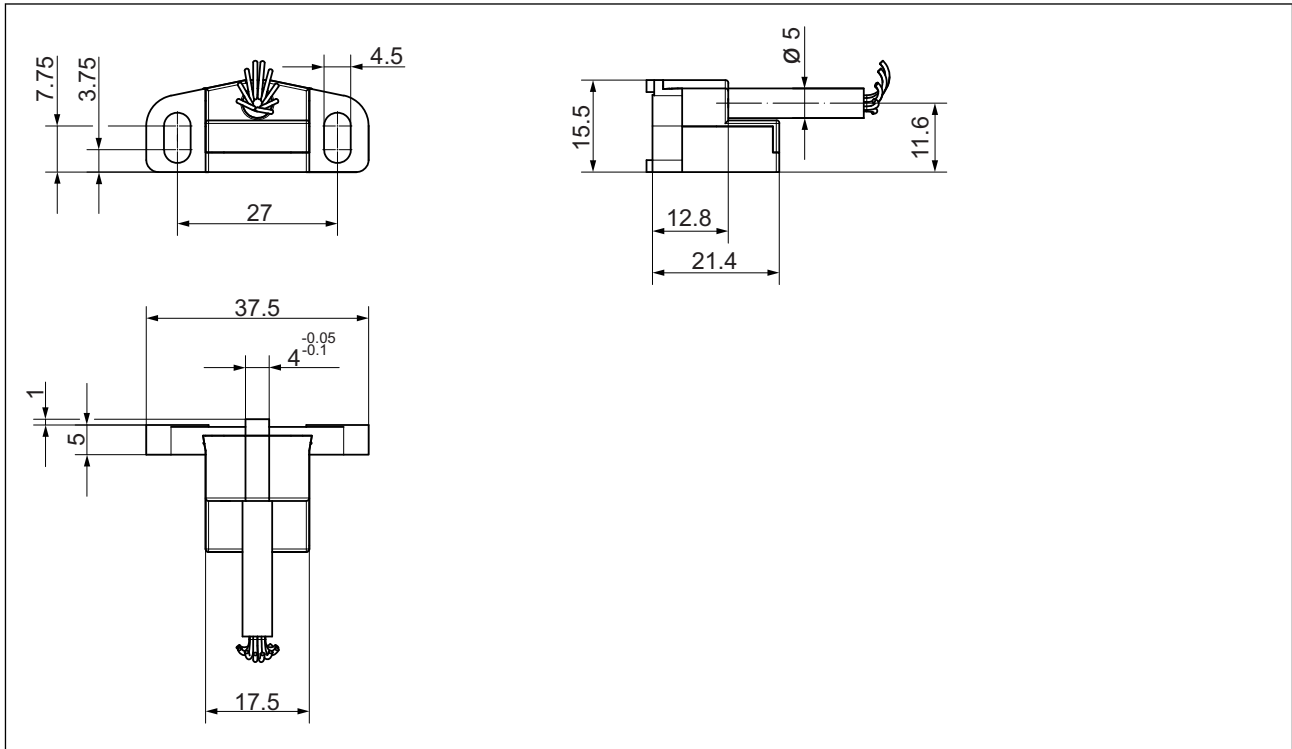

# GEL 2444M

## Hole pattern and installation dimensions

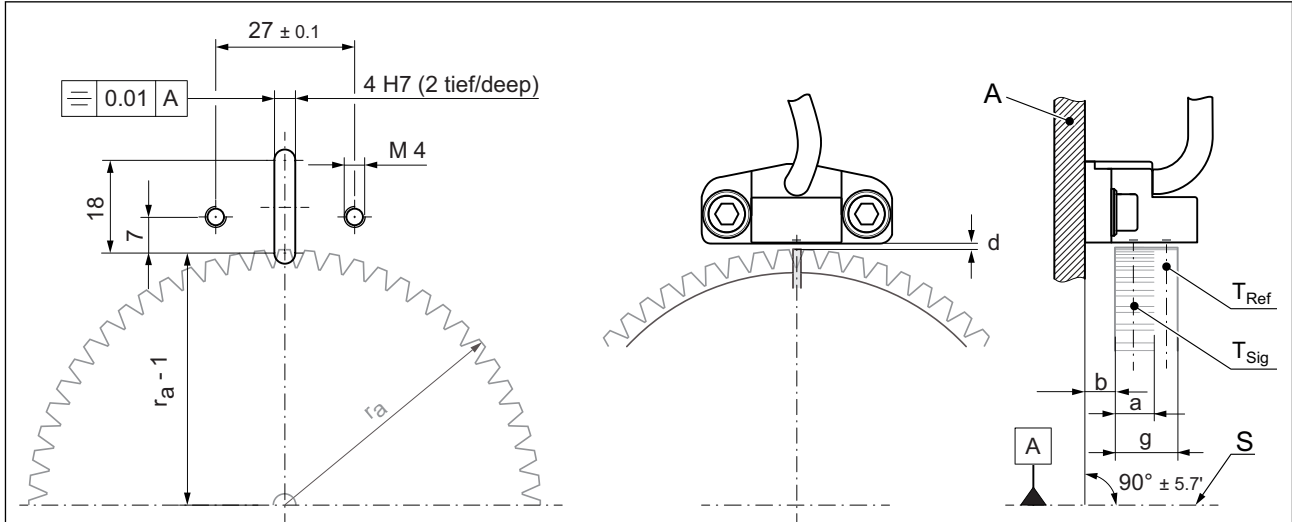

All dimensions in millimeters

- a Width of the signal track (depending on the target wheel)
- b Distance from mounting surface to target wheel: depending on the target wheel geometry (for example, width of signal track)
- d Air gap: depending on the module (→ page 8)
- g Target wheel width
- $r_a = d_a/2$  (with  $d_a$  = target wheel tip circle diameter)
- A Mounting device
- S Center line machine shaft/target wheel
- $T_{Ref}$  Reference track (target wheel)
- $T_{Sig}$  Signal track (target wheel)

### Installation dimensions for standard target wheels

Dimension	ZAN	ZAZ
g	10	10
$a_{1/2}$	4	6
$a_N$	4	4
b	$7.5 \pm 0.5$	$7.5 \pm 0.5$

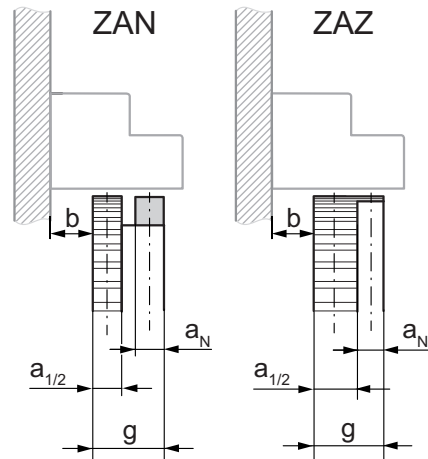

## Type code

<b>2444</b>	<b>Signal pattern</b>	
	<b>M</b>	MHSSI (Mitsubishi High Speed Serial Interface) 2.5 Mbit
	<b>Reference mark</b>	
	<b>N</b>	Lug <sup>(1)</sup>
	<b>Z</b>	Tooth on tooth
	<b>Optional extras</b>	
	<b>H</b>	Resolution configurable up to 26 bits, independent of the maximum speed.
	<b>P</b>	Resolution configurable up to 19 bits, depending on the maximum speed.
	<b>Cable outlet MiniCODER<sup>(2)</sup></b>	
	<b>G</b>	Axial
<b>Module<sup>(3)</sup></b>		
<b>3</b>	m= 0.3	
<b>4</b>	m= 0.4	
<b>5</b>	m= 0.5	
<b>Connection type</b>		
<b>K</b>	Flying lead <sup>(4)</sup>	
<b>Z</b>	10-pin male connector (only available as cable length 100/120/200/250)	
<b>Cable length L</b>		
<b>030</b>	0.3 m	
<b>050</b>	0.5 m	
<b>100</b>	1.0 m	
<b>120</b>	1.2 m	
<b>150</b>	1.5 m	
<b>200</b>	2.0 m	
<b>250</b>	2.5 m	
<b>Cable design for temperature sensor (2 m)</b>		
<b>-</b>	Without temperature sensor cable	



For MiniCODERs with optional extras **H** or **P** the resolution and the number of teeth can be configured with the mobile service unit GEL 211CST4\_2M. You can find the factory settings on → [page 10](#). Other factory settings are available upon request.

If you have any questions, please contact our Customer Support team (e-mail: [support@lenord.de](mailto:support@lenord.de)) or one of our company locations (→ [page 20](#)).



Technical information on MiniCODERs with other signal patterns is available online at [www.lenord.com](http://www.lenord.com) or can be requested from our support team ([support@lenord.de](mailto:support@lenord.de)).

(1) MiniCODERs that scan a reference mark "N" (lug) must be recalibrated with the mobile service unit during commissioning.

(2) Other cable outlets upon request

(3) Other modules upon request

(4) The delivery takes place with connected test connector from Lenord+Bauer.

# GEL 2449M

## Technical data measuring system

	GEL 2449M <sub>...1</sub>	GEL 2449M <sub>...4</sub>
<b>Target wheel</b>		
Material	Ferromagnetic steel	
Target wheel width	10.0 mm	
Reference mark	Tooth (Z)	
Module m <sup>(1)</sup>	1.0	0.4
<b>Geometric data</b>		
Nominal air gap	0.50 mm ± 0.03 mm	0.20 mm ± 0.02 mm

<sup>(1)</sup> Other modules upon request

## Technical data GEL 2449M

Electrical data	
Supply voltage $U_B$ (polarity reversal protected, overvoltage protected)	5 V DC $\pm$ 5 %
Current consumption (without load)	$\leq$ 80 mA
Digital interface	RS-485 with Mitsubishi protocol: MHSSI (Mitsubishi High Speed Serial Interface) 2.5 Mbit (RS-422/RS-485 compliant)
Signal identifiers of the interface	Request (RQ): Data request signal from the higher level control system Data (data): Data output from the MiniCODER as a response to the data request signal
Data transmission rate	2.5 Mbit/s
Power consumption without load	$\leq$ 0.5 W
Power-on time	< 0.5 s
Mechanical data	
Housing material	Zinc die casting
Weight	100 g
Maximum permissible rotational speed	$\leq$ 100,000 min <sup>-1</sup> (1)
Cable data	
Cable structure (number of cores x core cross-section)	9 x 0.15 mm <sup>2</sup> [25 AWG]
Cable diameter	5 mm
Minimum bending radius	25 mm
Maximum permissible cable length	$\leq$ 30 m (2)
Ambient data	
Working temperature range	0 °C to +70 °C
Operating and storage temperature range	-30 °C to +105 °C
Degree of protection	IP 68
Dielectric strength	500 V AC; as per DIN EN 61439-1
Electromagnetic compatibility	Electromagnetic emission DIN EN 61000-6-4; DIN EN 61000-6-3 Electromagnetic immunity DIN EN 61000-6-2; DIN EN 61000-6-1
Vibration resistance	200 m/s <sup>2</sup> (EN 60068-2-6)
Shock resistance	2000 m/s <sup>2</sup> (EN 60068-2-27)
MTTF FIT	3,828,120 h at 55 °C 261 10 <sup>-9</sup> h <sup>-1</sup> at 55 °C
Approvals	
European Economic Area	Conformity in accordance with EMC Directive 2014/30/EU <b>CE</b>

(1) Depending on the selected optional extras Mechanically permissible speed depending on the design of the target wheel (see Technical Information ZAx/ZFx (DS51-ZAx/ZFx).

(2) Consider voltage drop on the power supply cable; recommended cable length: maximum 2.5 m (no twisted pair)

# GEL 2449M

## Optional extras H

### Configuration

The number of teeth configured in the MiniCODER with optional extras H must match the number of teeth of the target wheel. The resolution is dependent of the maximum speed. The maximum configurable resolution is 26 bits/0.0000054° (67,108,864 positions per revolution).

### Factory settings<sup>(1)</sup>

Designation	Module 4 (m= 0.4)	Module 1 (m= 1.0)
Positions per revolution	16777216	16777216
Resolution	24 bit/0.0000215°	24 bit/0.0000215°
Target wheel tooth number	192	75

## Optional extras P

### Configuration

The number of teeth configured in the MiniCODER with optional extras P must match the number of teeth of the target wheel. The resolution is dependent of the number of teeth of the target wheel and the maximum speed. The maximum configurable resolution is 19 bits/0.00068° (524288 positions per revolution).

### Resolution for various applications<sup>(2)</sup>

Application	Standard		Rotational speed					Positioning
Interpolation per tooth cycle	512		256					1024
Target wheel tooth number	128	192	160	204	256	384	512	512
Maximum rotational speed (min <sup>-1</sup> ) <sup>(3)</sup>	41199	27466	65918	51700	41199	27466	20599	5150
Positions per revolution	65536	65536	32768	32768	65536	65536	131072	524288
Resolution	16 bit/0.00549°	16 bit/0.00549°	15 bit/0.0110°	15 bit/0.0110°	16 bit/0.00549°	16 bit/0.00549°	17 bit/0.00274°	19 bit/0.00068°

### Calculation of the maximum rotational speed

$$\text{Maximum rotational speed} = \frac{2.7 \cdot 10^9}{\text{Number of teeth} \cdot \text{Interpolation}} \text{ min}^{-1}$$

### Factory settings<sup>(1)</sup>

Designation	Module 4 (m= 0.4)	Module 1 (m= 1.0)
Interpolation per tooth cycle	512	512
Target wheel tooth number	192	75

### Assignment direction of rotation



(1) Other factory settings are available upon request.

(2) Configuration with the mobile service unit GEL 211CST

(3) The maximum speed is limited by the internal electronics. The maximum mechanical speed depends on the selection of the target wheel.



## Dimensional drawings

All dimensions in millimeters; general tolerance DIN ISO 2768 – mK

### Dimensional drawing – cable outlet MiniCODER: Tangential left (L)

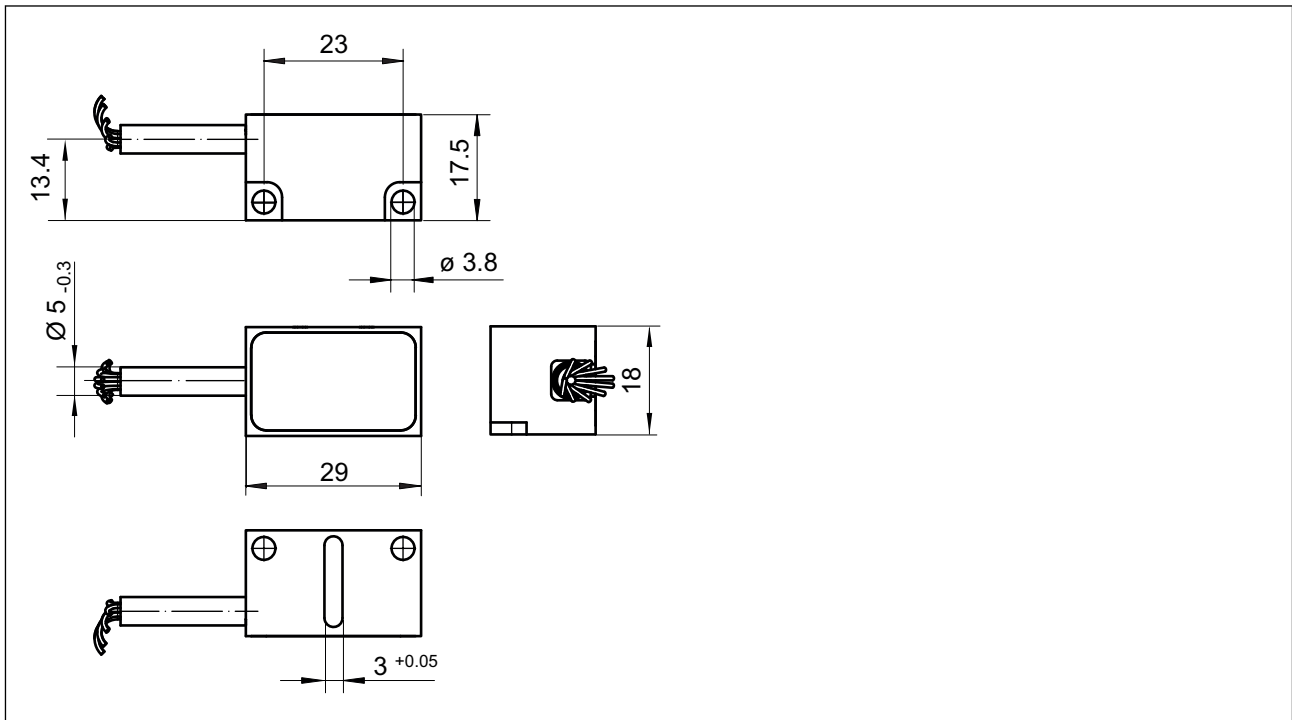

# GEL 2449M

## Hole pattern and installation dimensions

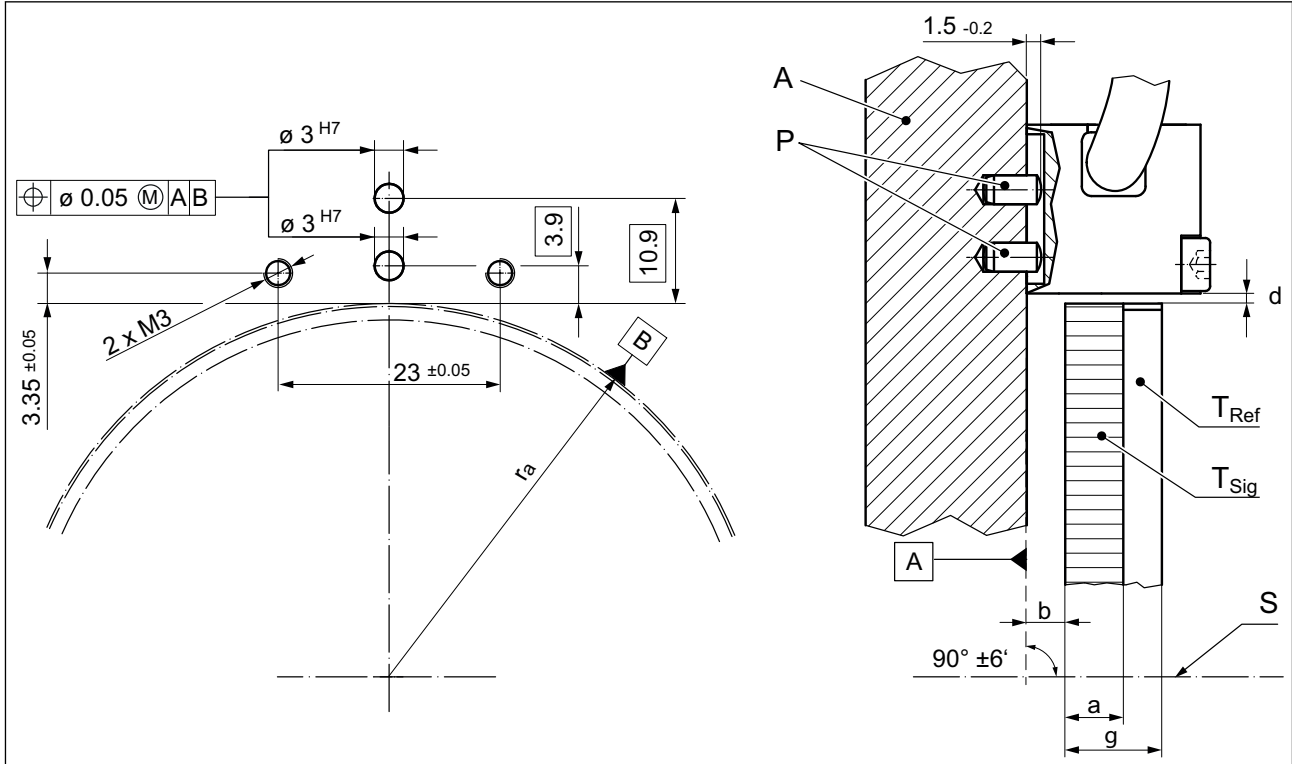

All dimensions in millimeters

- a Width of signal track: 6.0 mm
- b Distance from mounting surface to target wheel: depending on the target wheel geometry (for example, width of signal track)
- d Air gap: depending on the module ([→ page 14](#))
- g Target wheel width
- $r_a = d_a/2$  (with  $d_a$  = target wheel tip circle diameter)
- A Mounting device
- P Positioning pins M3
- S Center line machine shaft/target wheel
- $T_{Ref}$  Reference track (target wheel)
- $T_{Sig}$  Signal track (target wheel)

### Installation dimensions for standard target wheels

Dimension	ZAZ
g	10
$a_{1/2}$	6
$a_N$	4
b	$4 \pm 0.2$

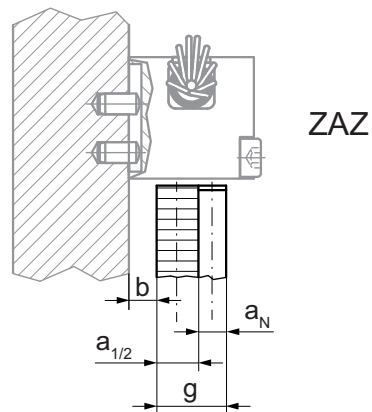

## Type code

<b>2449</b>	<b>Signal pattern</b>	
	<b>M</b>	MHSSI (Mitsubishi High Speed Serial Interface) 2.5 Mbit
	<b>Reference mark</b>	
	<b>Z</b>	Tooth on tooth
	<b>Optional extras</b>	
	<b>H</b>	Resolution configurable up to 26 bits, independent of the maximum speed.
	<b>P</b>	Resolution configurable up to 19 bits, depending on the maximum speed.
	<b>Cable outlet MiniCODER</b>	
	<b>L</b>	Tangential, cable outlet left
	<b>Module <sup>(1)</sup></b>	
<b>1</b>	m= 1.0	
<b>4</b>	m= 0.4	
<b>Connection type</b>		
<b>K</b>	Flying lead <sup>(2)</sup>	
<b>Z</b>	10-pin male connector (only available as cable length 100/120/200/250)	
<b>Cable length L</b>		
<b>030</b>	0.3 m	
<b>050</b>	0.5 m	
<b>100</b>	1.0 m	
<b>120</b>	1.2 m	
<b>150</b>	1.5 m	
<b>200</b>	2.0 m	
<b>250</b>	2.5 m	
<b>Cable design for temperature sensor (2 m)</b>		
<b>-</b>	Without temperature sensor cable	

**i** For MiniCODERs with optional extras **H** or **P** the resolution and the number of teeth can be configured with the mobile service unit GEL 211CST4\_2M. You can find the factory settings on → [page 16](#). Other factory settings are available upon request.

If you have any questions, please contact our Customer Support team (e-mail: [support@lenord.de](mailto:support@lenord.de)) or one of our company locations (→ [page 20](#)).

**i** Technical information on MiniCODERs with other signal patterns is available online at [www.lenord.com](http://www.lenord.com) or can be requested from our support team ([support@lenord.de](mailto:support@lenord.de)).

<sup>(1)</sup> Other modules upon request

<sup>(2)</sup> The delivery takes place with connected test connector from Lenord+Bauer.

This document and contents are the intellectual property of Lenord, Bauer & Co. GmbH. Without the written consent of Lenord, Bauer & Co. GmbH, the disclosure and forwarding to third parties as well as any exploitation of the contents, including the registration of intellectual property rights, is prohibited.



---

Lenord, Bauer & Co. GmbH	Lenord+Bauer Italia S.r.l.	Lenord+Bauer USA Inc.	Lenord+Bauer
Dohlenstraße 32	Via Gustavo Fara, 26	32000 Northwestern Highway	Automation Technology (Shanghai) Co.,Ltd.
46145 Oberhausen	20124 Milano	Suite 150	Block 42, Room 302, No.1000, Jinhai Road
Germany	Italy	Farmington Hills, MI 48334	201206 Shanghai
Phone +49 (0)208 9963-0	Phone +39 340 1047184	USA	China
<a href="http://www.lenord.de">www.lenord.de</a>	<a href="http://www.lenord.com">www.lenord.com</a>	Phone +1 248 446 7003	Phone +86 21 50398270
		<a href="http://www.lenord.com">www.lenord.com</a>	<a href="http://www.lenord.cn">www.lenord.cn</a>