

General

- Application-proven speed sensor using magnetic scanning
- Maintenance- and wear-free operation by contactless rotary motion measuring
- Wide measuring range for reliable detection of creeping without pulse loss and also for fast rotary motion
- Detection of direction by evaluating two channels with 90° phase offset



Features

- Ferromagnetic target wheel module: 1.00 to 2.00
- High-speed sensor with up to 40 kHz
- Suitable for asynchronous motor applications
- ASIL B (D) compliant (ISO 26262) or SIL 2 to SIL 3 for safety applications (on request by selectable error detection of output signals)

Advantages

- Tolerant behavior to assembly deviations thanks to advanced calibration technology
- Cost-effective
- Suitable for rough environments and extreme temperatures
- Wide operating temperature range from -40 °C to +125 °C
- Easy to install due to large measuring distance
- Degree of protection: IP 67 sensor housing

Field of application

- High-resolution detection of rotational speed and direction of rotation in motors, vehicle chassis or directly on wheels, especially robust for heavy-duty applications.
 - On- and off-road industrial vehicles
 - Agricultural vehicles
 - Special purpose machine construction

Do you have special requirements regarding flange shape, shaft length, number of channels, cable protection, cable outlet, connector assembly or EMC concept?

Talk to us. Our experts can design the optimal solution for your application from an extensive modular system and will be pleased to advise you how to customize your solution in the most cost-efficient way.

Write to support@lenord.de or call +49 208 9963-215.

Right to technical changes and errors reserved.

Technical data

Power supply	Option A 5 V	Option B 24 V
Electrical data		
Supply voltage U_B	5 V DC \pm 10 % (4.5 to 5.5 V DC)	4.5 to 24 V DC
Current consumption I_B (without load)	Maximum: 30 mA	Maximum: 70 mA
Frequency range (input frequency)	Maximum: 40 kHz	
Duty cycle	<ul style="list-style-type: none"> ■ Minimum: 40 % ■ Typical: 50 % ■ Maximum: 60 % 	
Phase offset ⁽¹⁾	<ul style="list-style-type: none"> ■ Minimum: 70° ■ Typical: 90° ■ Maximum: 110° 	
Mechanical data		
Housing material	Stainless steel (aluminum and brass possible upon request)	
Flange material	Stainless steel (aluminum and brass possible upon request)	
Sensor weight incl. 2 m cable length	approx. 140 g	
Environmental testing		
Working and operating temperature ⁽²⁾	-40 °C to +125 °C	
Storage temperature	-40 °C to +125 °C	
Dielectric strength	500 V AC/750 V DC (DIN EN 50155:2022-06)	
Electromagnetic compatibility ⁽³⁾	DIN EN 61000-4-2:2009-12 (only ESD handling) DIN EN 61000-4-4:2013-04 (fast transients and burst) VO043644-21-100941 (UNECE R10) VW TL81000 (2021-19) - Interference Emission Antennas (RE-Test) - Interference Immunity Antenna ALSE - Interference Immunity Current Injection (BCI)	
Salt spray test	ISO 9227-11	
Vibration resistance	ISO 16750-3	
Chemical loads	ISO 16750-5	
Degree of protection on measuring side ⁽⁴⁾	IP 67	
Vibration resistance	DIN EN 61373:2011-04 (shocks and vibration) DIN EN 60068-2-6:2008-10 (sinusoidal vibration)	
MTTF value	> 2,000,000 at 55 °C	
Applicable standards		
Environmental influences	DIN EN 60068-2-1:2008-01 (cold) DIN EN 60068-2-2:2008-05 (dry heat) DIN EN 60068-2-14:2010-04 (temperature change) DIN EN 60068-2-78:2014-02 (humid heat)	
Requirements for the target wheel		
Material	Ferromagnetic steel	
Tooth form	Involute gear teeth as per DIN 867 (others upon request)	
Width	\geq 10 mm (smaller upon request)	
Module m	1.00 / 1.25 / 1.50 / 1.75 / 2.00	
Air gap	see air gap table, page 8	

(1) High-precision phase displacement available as an option

(2) Short period for extreme temperatures

(3) Observe EMC notes in the mounting/operating instructions

(4) Degree of protection on the cable outlet side depends on cable gland or cable protection

Output signals

Description

The SEI10 is a sensor for rotational speed and position detection of ferromagnetic target wheels in electric motors for automotive and industrial applications.

The sensor has two independent differential channels. The sensor is able to eliminate the effects of magnetic and system offsets and detect false output transitions caused by vibrations in electric motors at startup and low speed. There are different signal output patterns to control rotational speed and direction of rotation with high accuracy.

Advanced calibration techniques are used to optimize signal offset and amplitude. This makes the sensor very insensitive to variations in air gap, speed and temperature.

The sensor is available for a variety of applications requiring two-phase rotational speed and position signals or simultaneous high-resolution rotational speed and direction information. Selectable error detection mode options are available upon request to realize ASIL B, ASIL B (D), SIL 2 or 3 applications.

Output signals

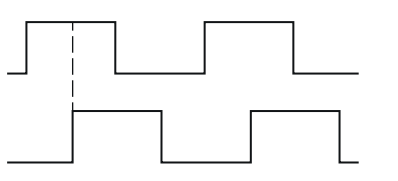
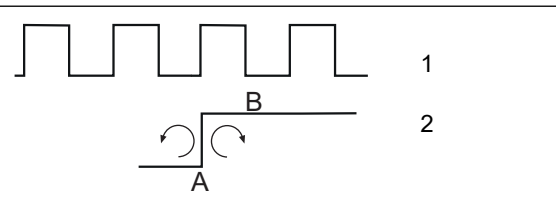
Output signals		Supply voltage	Pulse diagram
NPN	2 channels, 90° phase offset	4.5 V to 24 V	
NPNQ	Open Collector track 1 with double frequency, track 2 for direction of rotation	4.5 V to 24 V	 <p>A First switching point after change of direction B $V_{OUT (HIGH)}$</p>

Output signals

Safety functionality, upon request

Output signals		Supply voltage	Pulse diagram
NPNA	2 channels, 90° phase offset	Low Signal: 1.2 to 3.6 V High Signal: 8.4 V to 10.8 V	
	Internal diagnostics trigger error status ⁽¹⁾ . High-voltage signal	11.4 V to 12,6 V > 1 ms	
	Error in the IC output control Medium voltage signal	3.6 V to 8,4 V > 1 ms	
	Short circuit of output to ground Low-voltage signal	0 V to 1,2 V > 1 ms	

All values are valid at a pull-up resistor of 1 kΩ

⁽¹⁾ Refer to the safety manual to determine the error causes.

Technical drawings

All dimensions in mm, general tolerance DIN ISO 2768 mK

Dimensional drawing

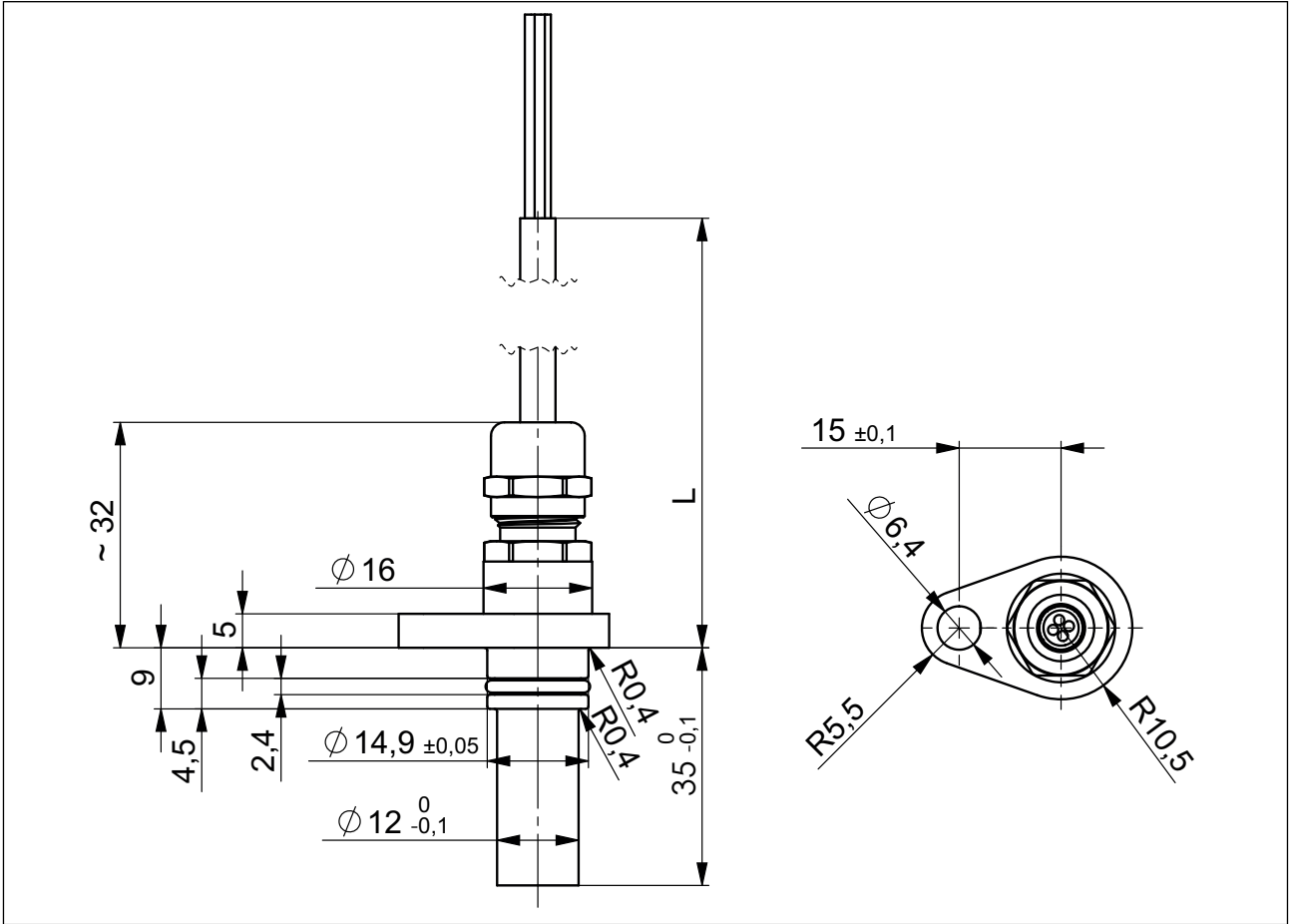

Technical drawings

All dimensions in mm, general tolerance DIN ISO 2768 mK

Assembly drawing

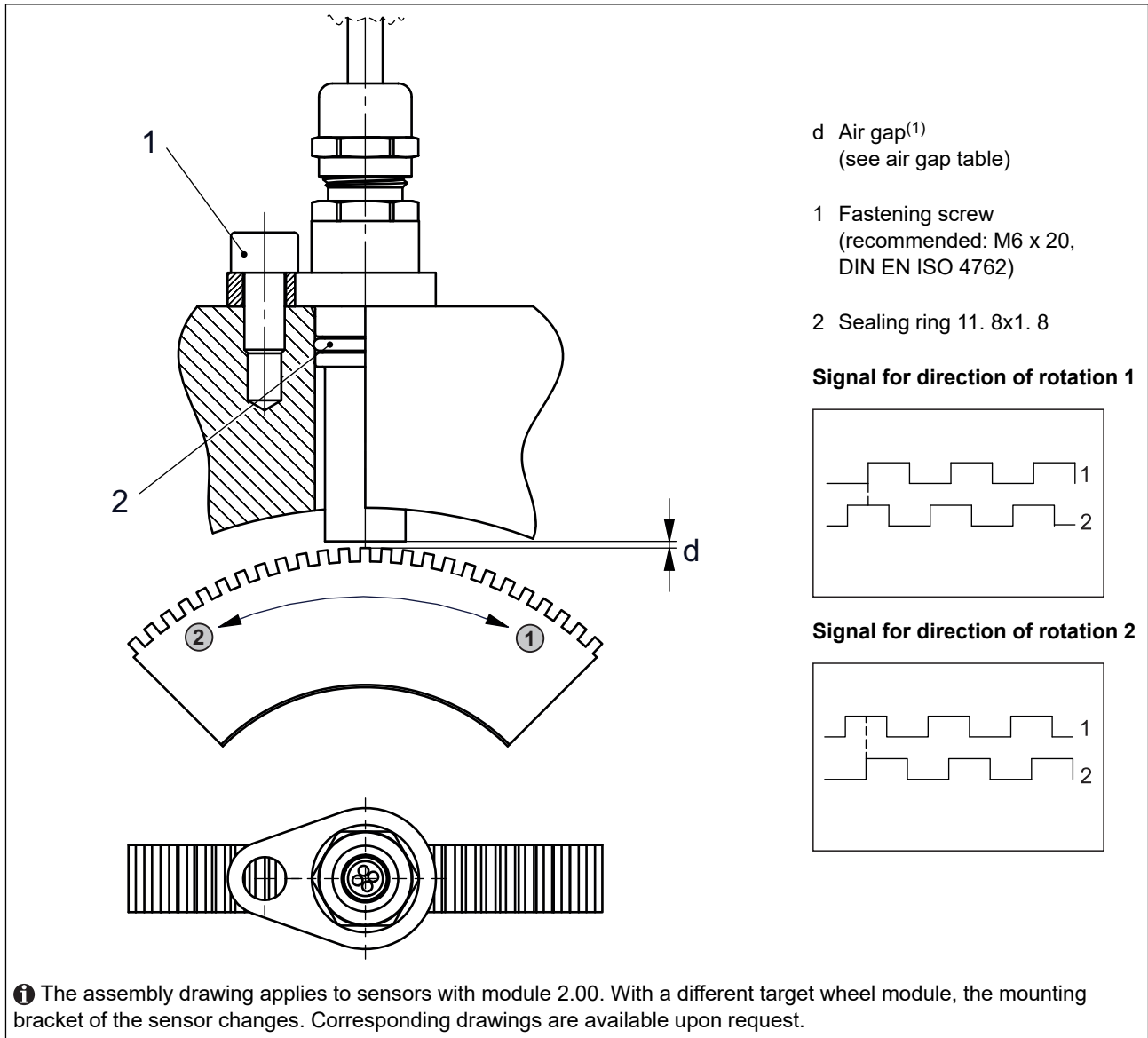

Assembly notes

- i** For proper assembly, always follow all instructions and directions contained in the sensor product information.
- Recommended cable fixation: 300 mm from the connector
- Tightening torque for M6 screws depending on threaded bore and fastening material
- The EMC notes in the product information must be observed.
- Screening concept:** Should the electromagnetic environment require special screening concepts, Lenord+Bauer offers support based on extensive knowledge and experience in integrating the sensor into the screening concept of the application.

⁽¹⁾ depending on signal pattern and module

Hole pattern

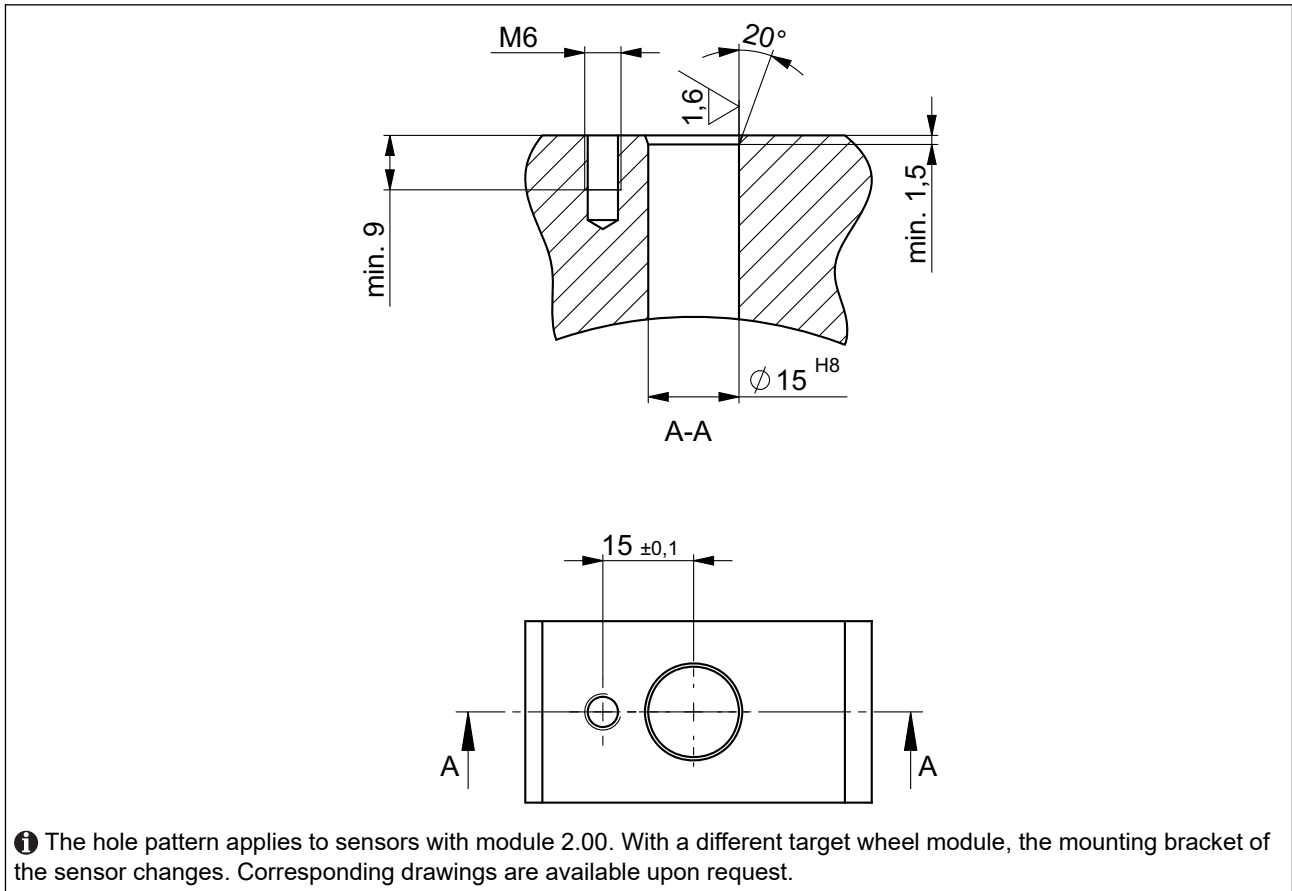

Air gap table

Air gap table

Module	Permissible air gap	Nominal air gap	max. permissible radial runout
1.00	0.2 to 0.8 mm	0.5 mm	± 0.3 mm
1.25	0.2 to 1.2 mm	0.7 mm	
1.50	0.2 to 1.6 mm	0.9 mm	
1.75	0.2 to 2.0 mm	1.2 mm	
2.00	0.2 to 2.4 mm	1.5 mm	

Cable assignment

Function	Color
Track 2/direction of rotation	white
Track 1	yellow
UB	black
GND	blue

Type code

GEL SEI10	Flange mounting	
	A	Simple screw connection
	Diameter	
	12	Tube diameter in mm
	Power supply	
	A	5 V DC \pm 10 % (4.5 to 5.5 V DC)
	B	24 V (4.5 to 24 V DC)
	Module m	
	100	m= 1.00
	125	m= 1.25
	150	m= 1.50
	175	m= 1.75
	200	m= 2.00
	Output	
0	NPN: Open Collector track 1 and track 2	
1	NPNQ: Open Collector track 1 with double frequency, track 2 for direction of rotation	
2	NPNA: Open Collector track 1 and 2, error detection for safety applications ⁽¹⁾	
Setting		
A	Standard phase setting ⁽²⁾	
Cable length L⁽³⁾		
01000	Cable length 1000 mm	
02000	Cable length 2000 mm	
Cable		
A	Cable without screening	
B	Cable with screening (not connected on sensor side)	
Cable connection		
00	Flying lead	
01	Connectors upon request	
Cable protection		
A	Without cable protection	
B	With cable protection	
Housing material		
E	Stainless steel	

Note: A Y-number is assigned for a customer-specific special version. A special design SEI10Yxxx is manufactured according to drawing or application description.

⁽¹⁾ In preparation

⁽²⁾ Ideal conditions depend on the user application

⁽³⁾ Further cable lengths upon request

Your notes

This document and contents are the intellectual property of Lenord, Bauer & Co. GmbH. Without the written consent of Lenord, Bauer & Co. GmbH, the disclosure and forwarding to third parties as well as any exploitation of the contents, including the registration of intellectual property rights, is prohibited.



Lenord, Bauer & Co. GmbH	Lenord+Bauer Italia S.r.l.	Lenord+Bauer USA Inc.	Lenord+Bauer
Dohlenstraße 32	Via Gustavo Fara, 26	32000 Northwestern Highway	Automation Technology (Shanghai) Co.,Ltd.
46145 Oberhausen	20124 Milano	Suite 150	Block 42, Room 302, No.1000, Jinhai Road
Germany	Italy	Farmington Hills, MI 48334	201206 Shanghai
Phone +49 (0)208 9963-0	Phone +39 340 1047184	USA	China
www.lenord.de	www.lenord.com	Phone +1 248 446 7003	Phone +86 21 50398270
		www.lenord.com	www.lenord.cn